



Die Cast Aluminium housing, ideal for rough industrial environments



Highly legible LED large display (30mm), easy to read from a distance

IE-1700 SERIES

Crane Scale

The IE-1700 Crane Scale is a light weight, portable and easy to use crane scale. Equipped with a wireless remote control function which makes operation more efficient and safe. Use in recycling or any other light industrial applications.

- Maximum Capacity: 1,000kg
- Rechargeable Battery operated
- Large LED Display
- Wireless remote control
- Robust Design, ideal for rough industrial environments



IE-1700 SERIES | Crane Scale

SPECIFICATIONS

Model	IE-1700 Series				
Max. Capacity (kg)	100	200	300	500	1,000
Readability (g)	50	100	100	200	500
External Resolution	1/2,000~1/3,000				
Max Tare	Full Tare				
Display Digits	5 Digits				
Display Type	LED (30mm)				
Operating Temp.	-10°C ~ 40°C				
Function Key	Power, Zero, Tare, Hold				
Remote Control Range	Min. 10m				
Power	AC adapter DC 9V, Rechargeable Battery				
Battery Life	Up to 50hrs				
Dimensions (mm)	225(W) x 130(D) x 375(H)		225(W) x 130(D) x 405(H)		
Product Weight (kg)	4		4.2		

FEATURES

- High external resolution
- High intensity Hook & Shackle, special load cell for safety installation
- Battery Operated
- Standard AC Adapter
- Die-Cast Aluminum Case
- On / Off, Zero, Tare, and Hold functions
- Low battery & Overload indication
- Easy-to-Read LED Display (30mm)
- Wireless Remote Control

DIMENSIONS

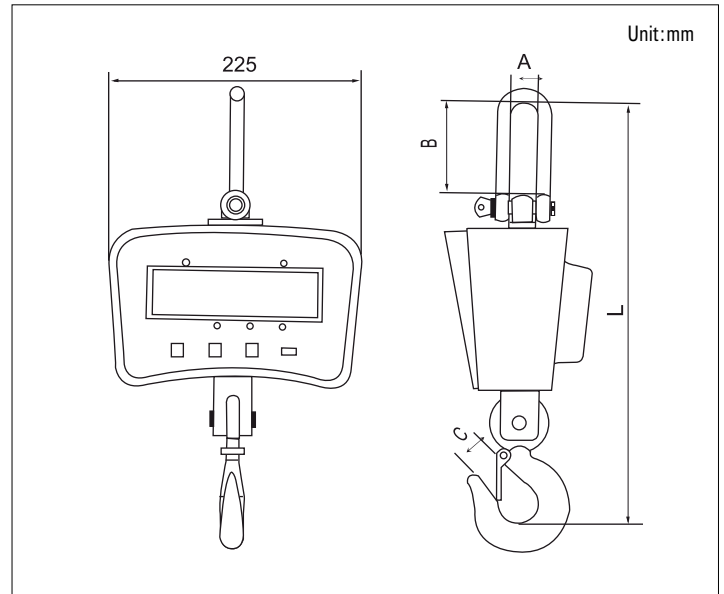

Model	IE-1700 Series				
Max. Capacity (kg)	100	200	300	500	1,000
L (mm)	335			360	
A (mm)	20			25	
B (mm)	65			75	
C (mm)	20			20	

CAS

UNIT 8, NORTHLINK, 459 TUFNELL ROAD
BANYO QLD 4014, AUSTRALIA

TEL: +61 (0)7 3267 7767 FAX: +61 (0)7 32 67 1818

EMAIL: sales@cassscale.com.au

<http://www.cassscale.com.au>

Specifications are subject to change for improvement without prior notice.